

# ZUBIOLA DIAMOND TOOLS SOLUTIONS

FRESAS DE PCD & PCBN PARA LA OPERACIÓN  
DE DESBASTE Y ACABADO.

FRAISES PCD & PCBN POUR L'OPÉRATION D'ÉBAUCHE ET FINITION.

*PCD & PCBN END MILLS FOR ROUGHING AND FINISHING OPERATION.*

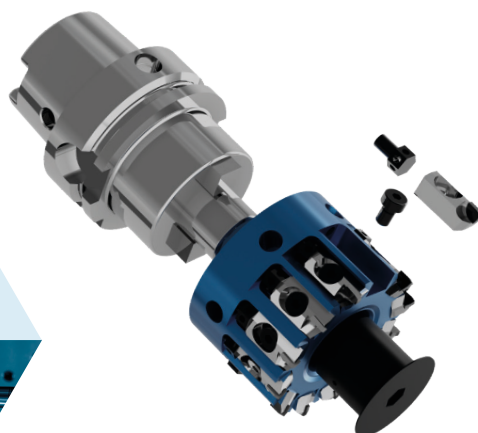

**CUALQUIERA QUE SEA SU NECESIDAD DE ACABADO Y RUGOSIDAD  
(Ra,Rz,Rt,Rmax,R,Rx), CONSÚLTENOS.**

**QUELQUE SOIT VOTRE BESOIN EN FINITION ET RUGOSITÉ (Ra, Rz, Rt,Rmax,R,Rx), CONTACTEZ-NOUS.**

*WHATEVER YOUR NEED FOR FINISH AND ROUGHNESS (Ra, Rz, Rt,Rmax,R,Rx), CONTACT US.*

**LE AYUDAREMOS EN LA BUSQUEDA DE LAS MEJORES CONDICIONES DE CORTE.**

**NOUS VOUS AIDERONS À TROUVER LES MEILLEURES CONDICIONS DE COUPE.**

*WE WILL HELP YOU IN YOUR SEARCH FOR THE BEST CUTTING CONDITIONS.*



**SURFACE ROUGHNESS REPORT** **ZUBIOLA** division de la empresa de ingeniería de maquinaria de precisión de la zona de la costa de Guipúzcoa de España **mm** Mediciones de Superficies de Maquinaria de Precisión

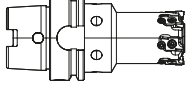

Customer:  
Tool reference:  
OF:  
Date:

**Roughness specification of the customer**

Ra (µm)	
Rz (µm)	
Rt (µm)	
Rmax (µm)	
R (µm)	
Rx (µm)	
Operation	Face milling
f (mm/z)	
S (rpm)	

**Tool information**

Tool diameter (mm) (A)	
Tool length (mm) (B)	
Teeth amount	
Teeth height difference (mm)	
Equilibration	at

**Simulation/experimental results**

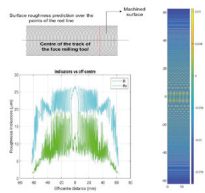

Measurement from the centre (mm)	R (µm) model	R <sub>z</sub> (µm) model
0		
15		
30		
45		

Measurement from the centre (mm)	R (µm) model	R <sub>z</sub> (µm) model
0		
15		
30		
45		

Measurement from the centre (mm)	R (µm) model	R <sub>z</sub> (µm) model
0		
15		
30		
45		

Comments



**ZUBIOLA**

Polígono Basterretxe, 44.  
(20720) Azkoitia -Gipuzkoa-Spain

Tf +34 943 157 056 / Fax. +34 943 150 026

[zubiola@zubiola.es](mailto:zubiola@zubiola.es)

[www.linkedin.com/company/zubiola](http://www.linkedin.com/company/zubiola)

**[www.zubiola.es](http://www.zubiola.es)**

